

**POLAR 52**

**VACUUM PACKAGING MACHINE**



**FEATURES**

- Standard with 2 seal bars: 2 x 520 mm (left/right)
- Standard double seal (two wires). Optional without extra costs: Cut-off or Wide seal (10 mm)
- Silicone holders easily removable for cleaning and maintenance purposes
- Pump capacity: 63 m<sup>3</sup>/h Busch vacuum pump
- Pump maintenance and cleaning program
- Machine cycle: 15-40 sec
- Standard Soft Air to protect the product and vacuum bag
- Standard Digital control with 10 program memory and Time control
- Flat work plate
- Comes with insert plates for a faster cycle and product adjustment
- Stainless steel exterior
- IP-65 Classification

**OPTIONS**

- 1-2 Cut-off seal
- Bi-active seal
- Sensor control
- Advanced Control System (ACS)
- Liquid control
- Gas flush (incl. pressed air connection)
- Preparation for external pump

**ACCESSORIES**

- Zebra ZD410 thermal label printer (only in combination with ACS)
- Inclined insert plate (for vacuum packing liquids and powders)
- Service kit for standard maintenance

**DESCRIPTION**

The robust, stainless steel Polar 52 vacuum packaging machine is standard equipped with a Busch vacuum pump. This floor model complies with CE standards.



Henkelman offers standard 3 year warranty.

# VACUUM PACAGING MACHINE POLAR 52 – SPECS

VACUUM PACKAGING MACHINE POLAR 52 – SPEC SHEET

## DIMENSIONS

In mm

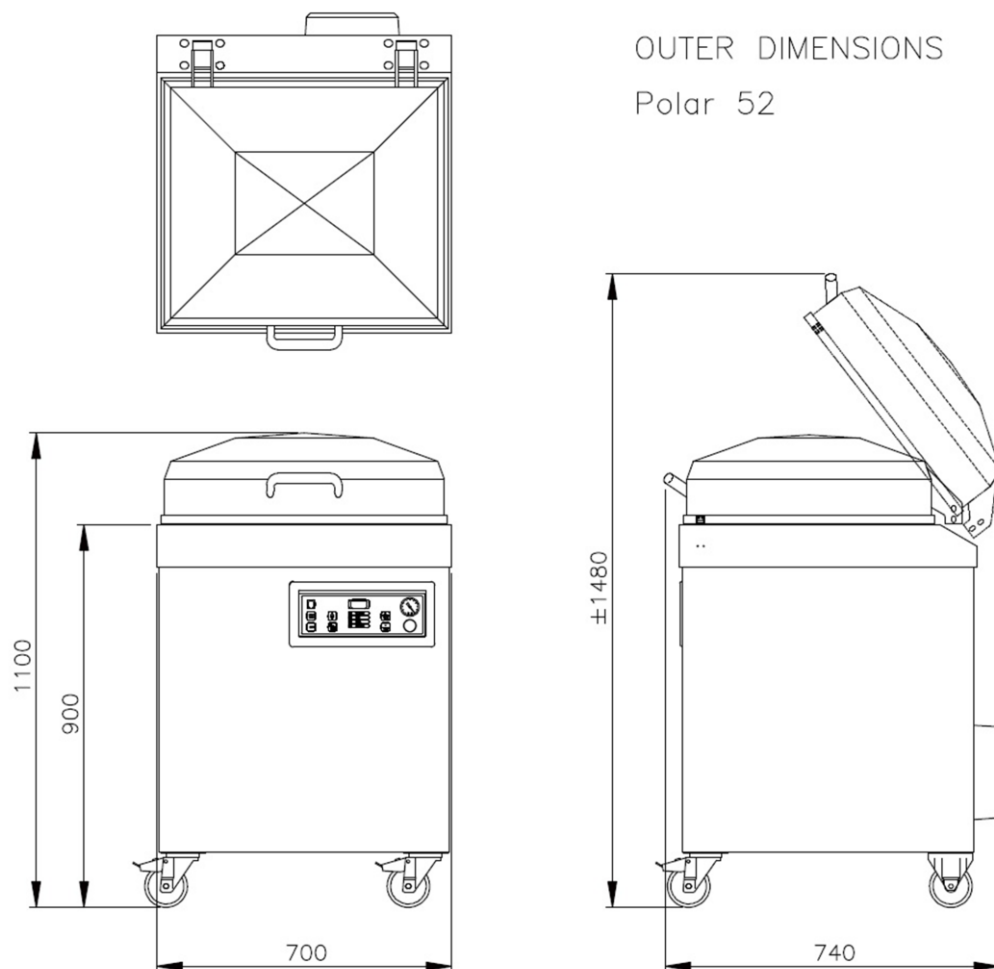

OUTER DIMENSIONS

Polar 52

Model	Dimensions (mm)		Voltage* (Hz)	Pump capacity (m <sup>3</sup> /h)	Power (kW)	Weight (kg)
	Chamber (usable space) L x W x H	Machine L x W x H				
Polar 52	520 x 500 x 200	740 x 700 x 1100	400V-3-50	63	2,4-3,5	183

\* Other voltages available



HENKELMAN BV  
Titaniumlaan 10  
5221 CK 's-Hertogenbosch  
The Netherlands

**Sales support**  
P +31 73 621 36 71  
E [info@henkelman.com](mailto:info@henkelman.com)  
**Service/technical support**  
P +31 73 621 36 71  
E [service@henkelman.com](mailto:service@henkelman.com)